



**Features**

- 1/3 inch IT CCD
- High Resolution : 600 TV Lines
- Built-in Fixed (f=3.8mm)
- Intelligent IR Technology
- Built-in IR LED(12EA) and Sensor(1EA)
- Min Illumination : Night(0.00Lux, IR LED On)
- Weather Proof Housing
- 50mm in Diameter



**DIMENSIONS**

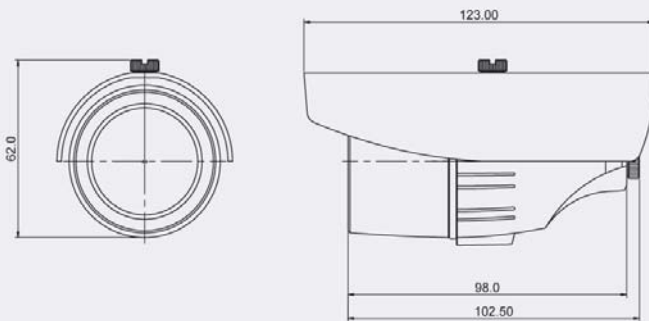

**SPECIFICATIONS**

Model	HIS-WBL-20S
Signal System	NTSC
Scanning System	2:1 Interlace
Scanning Frequency (H)	15.734 KHz
Scanning Frequency (V)	59.94 Hz
Image Sensor	1/3 Inch IT CCD
Total Pixels	811(H) x 508(V) 410K
Effective Pixels	768(H) x 494(V) 380K
Horizontal Resolution	600 TV Lines (BW 650TV Lines)
Video Output	Composite: 1.0V p-p, 75Ω, Unbalanced
S/N Ratio	More than 50dB(AGC Off)
Lens	Built-in Fixed Lens (f=3.8mm)
Min.Illumination	0.1 Lux (Color), 0.01 Lux (B/W), 0.00 Lux (IR LED On)
IR LED and Sensor	Intelligent IR Technology (850nm, 30), 12EA
IR LED Visible Range	Max. 15m
White Balance	Auto
Shutter Speed	1/60-1/120,000 sec.
Supplied Voltage	DC 12V
Dimensions	62.0 x 123.0mm
Weight	Approx. 600g